

RFLS2018035

1/4-20 UNC-2B *

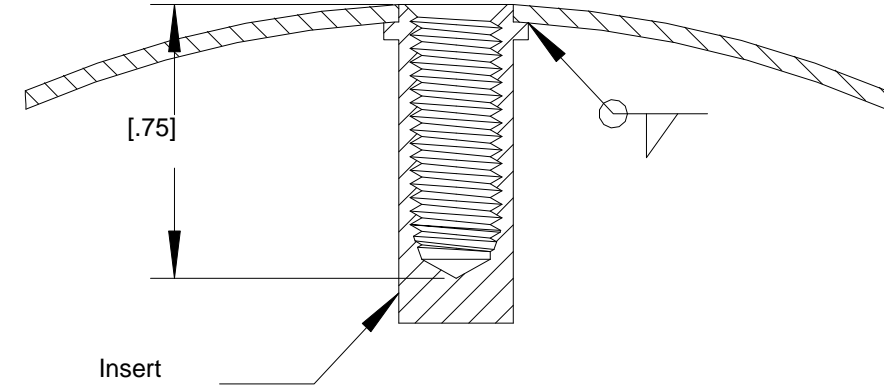

DETAIL B

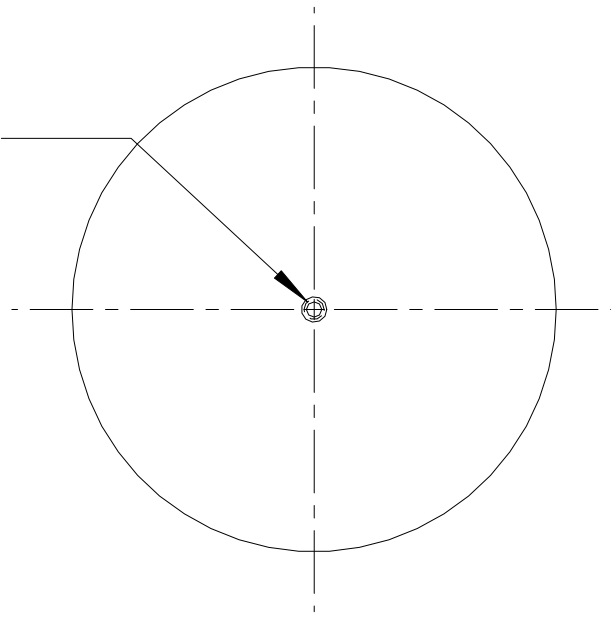
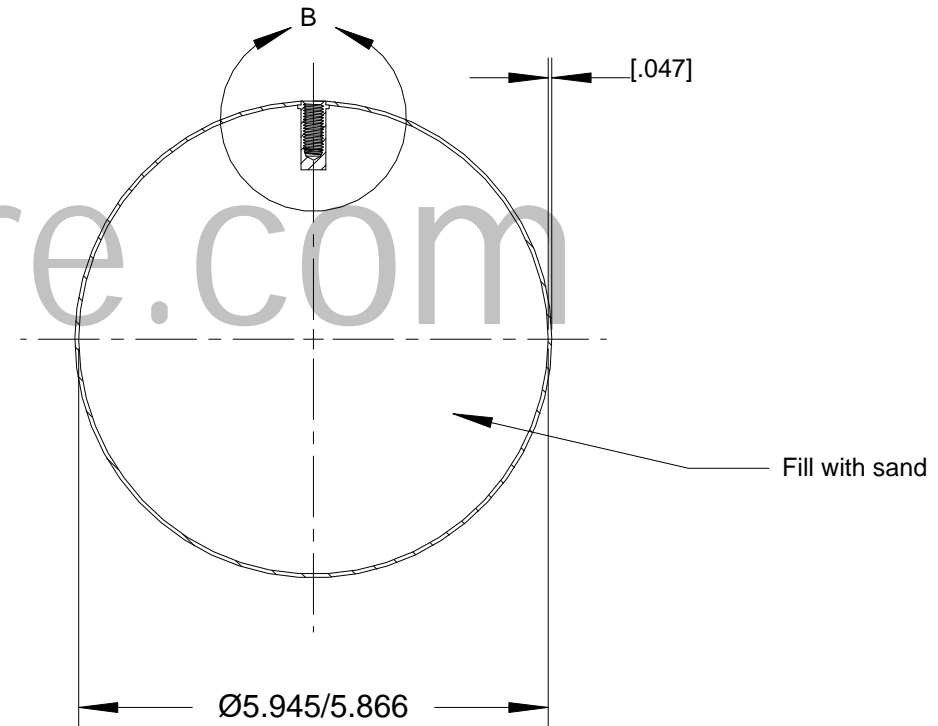
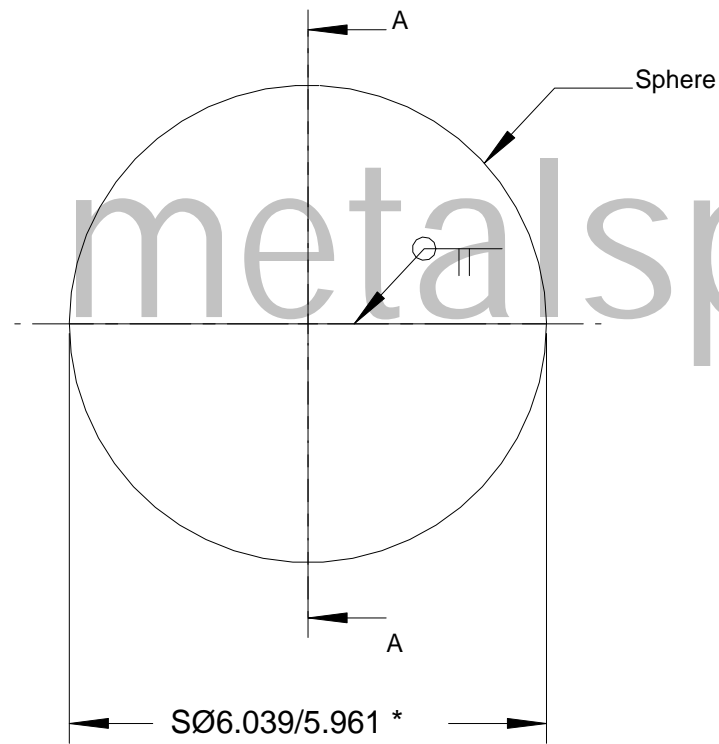

SECTION A-A

metalsphere.com

零件代号

借(通)用件登记

描图

描校

旧底图总号

底图总号

签字

日期

This Drawing is the Property of SHINY BALLS LTD. It contains confidential, proprietary information that is SHINY BALLS LTD. Do not disclose to or duplicate for others except as authorized by SHINY BALLS LTD.

Technology	Stamping Press	Standard	GBT 19867.1-2005
Finish	Mirror polished	Material	AISI304 stainless steel
DIMS IN INCH UNLESS STATED			

© 2018 SHINY® www.metalsphere.com Firepitball.com

stainless steel floating ball



Tolerances (Inch)
 .xx = ± .01
 .xxx = ± .005
 x° = ± 1°
 or As Noted

Scale
 N.T.S.

RFLS2018035

Drawn

TONY

DATE: 2018/03/19

Checked

TONY

DATE: 2018/03/19